



AKZ1710/..-3.81-GREEN



Technical Data

| Wire sizes | | Insulating Material | |
|---------------------------|----------------------|--|-----------------|
| Solid min | 0.14 mm ² | Material | PA 6.6 |
| Solid max | 1.5 mm ² | Flammability Class | UL 94 V-0 |
| Stranded (flexible) min | 0.14mm ² | Temperatures | |
| Stranded (flexible) max | 1.5 mm ² | Operating Temperature (without mech. load) | -40 °C - 105 °C |
| Stranded with Ferrule min | 0.25 mm ² | Store Temperature | -40 °C - 105 °C |
| Stranded with Ferrule max | 1.0 mm ² | Wave Soldering Process | |
| Dimensions | | Soldering Temperature, recommended | - |
| Stripped Length | 7.0 mm | Peak Soldering Time, recommended | - |
| Materials | | Reflow Process | |
| Clamp | Brass | Soldering Temperature, recommended | - |
| Screw | Bronze | Peak Soldering Time, recommended | - |
| Contact Spring | Bronze | | |

Colours

| | |
|---|-------------------------------|
|  | GREEN, RAL 6018 |
|  | LIGHT GREY, RAL 7035 |
|  | LIGHT GREEN, similar RAL 6018 |

Colours according to RAL, there may be variations on colour due to production conditions. Special colours on request.

Counterparts (Spacing 3.81 mm)



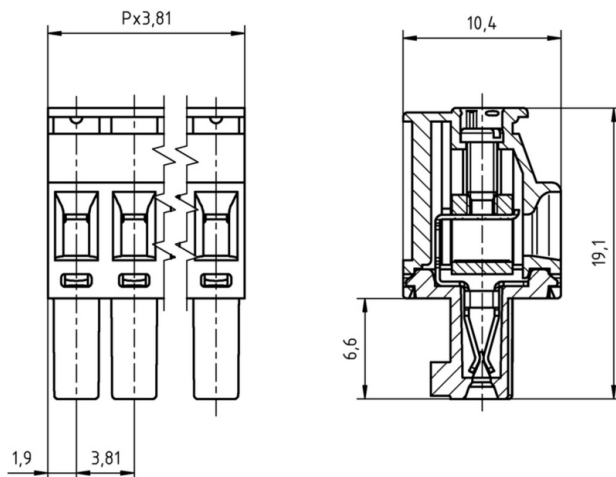

| Pin Strip | STLZ1550 | STLZ1570 | STLZ1590 |
|---|----------|----------|----------|
| In combination of connectors with different admission data, the lower value is valid. | | | |



Order Data (Spacing 3.81 mm)

| Poles | Width (mm) | Article Designation | Article Number | PU |
|-------|------------|-----------------------|----------------|-----|
| 2 | 7.62 | AKZ1710/2-3.81-GREEN | 51710020021 F | 200 |
| 3 | 11.43 | AKZ1710/3-3.81-GREEN | 51710030021 F | 200 |
| 4 | 15.24 | AKZ1710/4-3.81-GREEN | 51710040021 F | 200 |
| 5 | 19.05 | AKZ1710/5-3.81-GREEN | 51710050021 F | 200 |
| 6 | 22.86 | AKZ1710/6-3.81-GREEN | 51710060021 E | 100 |
| 7 | 26.67 | AKZ1710/7-3.81-GREEN | 51710070021 E | 100 |
| 8 | 30.48 | AKZ1710/8-3.81-GREEN | 51710080021 D | 50 |
| 9 | 34.29 | AKZ1710/9-3.81-GREEN | 51710090021 D | 50 |
| 10 | 38.10 | AKZ1710/10-3.81-GREEN | 51710100021 D | 50 |
| 11 | 41.91 | AKZ1710/11-3.81-GREEN | 51710110021 D | 50 |
| 12 | 45.72 | AKZ1710/12-3.81-GREEN | 51710120021 D | 50 |
| 13 | 49.53 | AKZ1710/13-3.81-GREEN | 51710130021 D | 50 |
| 14 | 53.34 | AKZ1710/14-3.81-GREEN | 51710140021 D | 50 |
| 15 | 57.15 | AKZ1710/15-3.81-GREEN | 51710150021 D | 50 |
| 16 | 60.96 | AKZ1710/16-3.81-GREEN | 51710160021 D | 50 |
| 17 | 64.77 | AKZ1710/17-3.81-GREEN | 51710170021 D | 50 |
| 18 | 68.58 | AKZ1710/18-3.81-GREEN | 51710180021 D | 50 |
| 19 | 72.39 | AKZ1710/19-3.81-GREEN | 51710190021 D | 50 |
| 20 | 76.20 | AKZ1710/20-3.81-GREEN | 51710200021 D | 50 |

Accessoires

| Figure | Designation | Article Number |
|--|--|-------------------------|
|  | Series AK(Z)1550 with pull relief | Order Data: on request |
|  | Bridge, 2-pole, BR/2-3.5/3.81-L7.5 | Order Data: 50000000015 |
|  | Bridge, 3-pole, BR/3-3.5/3.81-L7.5 | Order Data: 50000000016 |
|  | Bridge, 2-pole, insulated, BR/2-7.0/7.62-L7.5-LIGHT GREY | Order Data: 50000000018 |
|  | Bridge, 2-pole, angled, BR/2-3.5/3.81-H-L7.5 | Order Data: 50000000029 |

Ratings

| UseGroup | cRU [®] US | | | VDE | |
|----------------------|---------------------|---|-----------|---------------------------|---------------------------|
| | B | C | D | | |
| Rated Voltage | 300 V | - | 300 V | 160 V | |
| Rated Current | 8 A | - | 8 A | 8 A | |
| Overvoltage Category | | | | III | |
| Rated Wire Size | | | min | | max |
| - solid | AWG 28-16 | - | AWG 28-16 | 0.5 mm ² (6 A) | 1.5 mm ² (8 A) |
| - stranded | AWG 28-16 | - | AWG 28-16 | 0.5 mm ² (6 A) | 1.5 mm ² (8 A) |
| Torque | 0.25 Nm | - | 0.25 Nm | 0.25 Nm | |
| Screw Size | M2 | - | M2 | M2 | |
| Test Voltage | 1.60 kV | - | 1.60 kV | 2.5 kV | |
| Pollution Degree | | | | 3 | |