

# AKZ1200/..F-10.16-GREEN



A Phoenix Mecano Brand



## Technical Data

Wire sizes		Insulating Material	
Solid min	0.2 mm <sup>2</sup>	Material	PA 6.6
Solid max	4.0 mm <sup>2</sup>	Flammability Class	UL 94 V-0
Stranded (flexible) min	0.2mm <sup>2</sup>	<b>Temperatures</b>	
Stranded (flexible) max	2.5 mm <sup>2</sup>	Operating Temperature (without mech. load)	-40 °C - 105 °C
Stranded with Ferrule min	0.25 mm <sup>2</sup>	Store Temperature	-40 °C - 105 °C
Stranded with Ferrule max	2.5 mm <sup>2</sup>	<b>Wave Soldering Process</b>	
<b>Dimensions</b>		Soldering Temperature, recommended	-
Stripped Length	10.0 mm	Peak Soldering Time, recommended	-
<b>Materials</b>		<b>Reflow Process</b>	
Screw	Steel	Soldering Temperature, recommended	-
Screw, Flange	Steel	Peak Soldering Time, recommended	-
Contact Spring	Bronze		
Clamp Cage	Steel		
Excenter	Steel		

## Colours

	GREEN, RAL 6018
	PEBBLE GREY, RAL 7032
	LIGHT GREEN, similar RAL 6018

Colours according to RAL, there may be variations on colour due to production conditions. Special colours on request.

## Counterparts (Spacing 10.16 mm)

Pin Strip/Terminal Block		
STLZ950	AKZ5950	STLZ970

In combination of connectors with different admission data, the lower value is valid.

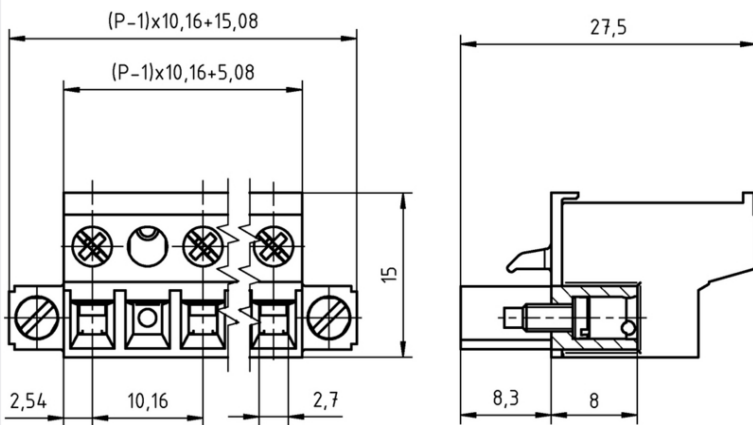

## Order Data (Spacing 10.16 mm)

Poles	Width (mm)	Article Designation	Article Number	PU
2	25.24	AKZ1200/2F-10.16-GREEN	51200022061 D	50
3	35.40	AKZ1200/3F-10.16-GREEN	51200032061 D	50
4	45.56	AKZ1200/4F-10.16-GREEN	51200042061 D	50
5	55.72	AKZ1200/5F-10.16-GREEN	51200052061 D	50
6	65.88	AKZ1200/6F-10.16-GREEN	51200062061 D	50
7	76.04	AKZ1200/7F-10.16-GREEN	51200072061 D	50
8	86.20	AKZ1200/8F-10.16-GREEN	51200082061 D	50
9	96.36	AKZ1200/9F-10.16-GREEN	51200092061 D	50
10	106.52	AKZ1200/10F-10.16-GREEN	51200102061 D	50

## Accessoires

Figure	Designation	Article Number
	Coding Star CS1-5.0/5.08-RED	Order Data: 50000000021
	Series AKZ1200 with pull relief	Order Data: on request

## Ratings

UseGroup	C <sup>RU</sup> US			VDE	
	B	C	D		
Rated Voltage	300 V	150 V	300 V	630 V	
Rated Current	15 A	15 A	10 A	12 A	
Overvoltage Category				III	
Rated Wire Size				min	max
- solid	AWG 22-12	AWG 22-12	AWG 22-12	0.5 mm <sup>2</sup> (5 A)	2.5 mm <sup>2</sup> (12 A)
- stranded	AWG 22-12	AWG 22-12	AWG 22-12	0.5 mm <sup>2</sup> (5 A)	2.5 mm <sup>2</sup> (12 A)
Torque	0.80 Nm	0.80 Nm	0.80 Nm	0.50 Nm	
Screw Size	M2.5	M2.5	M2.5	M2.5	
Test Voltage	1.60 kV	1.30 kV	1.60 kV	6.0 kV	
Pollution Degree				3	