

AKZ1200/..-5.08-GREEN

- 17 to 24 poles on request

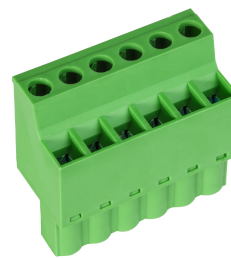

A Phoenix Mecano Brand



Technical Data

Wire sizes		Insulating Material	
Solid min	0.2 mm ²	Material	PA 6.6
Solid max	4.0 mm ²	Flammability Class	UL 94 V-0
Stranded (flexible) min	0.2mm ²	Temperatures	
Stranded (flexible) max	2.5 mm ²	Operating Temperature (without mech. load)	-40 °C - 105 °C
Stranded with Ferrule min	0.25 mm ²	Store Temperature	-40 °C - 105 °C
Stranded with Ferrule max	2.5 mm ²	Wave Soldering Process	
Dimensions		Soldering Temperature, recommended	-
Stripped Length	10.0 mm	Peak Soldering Time, recommended	-
Materials		Reflow Process	
Screw	Steel	Soldering Temperature, recommended	-
Contact Spring	Bronze	Peak Soldering Time, recommended	-
Clamp Cage	Steel		
Excenter	Steel		

Colours

- GREEN, RAL 6018
- LIGHT GREEN, similar RAL 6018

Colours according to RAL, there may be variations on colour due to production conditions. Special colours on request.

Counterparts (Spacing 5.08 mm)

Pin Strip/Terminal Block

STLZ950	STLZ950-HT	STLZ950-G-HT	STLZ970	STLZ990	AKZ950	AKZS950
---------	------------	--------------	---------	---------	--------	---------

In combination of connectors with different admission data, the lower value is valid.

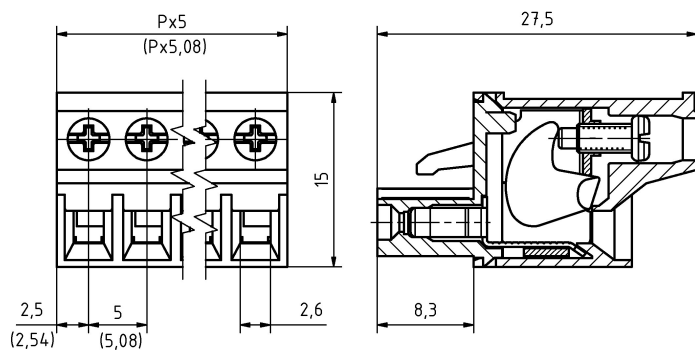

Order Data (Spacing 5.08 mm)

Poles	Width (mm)	Article Designation	Article Number	PU
2	10.16	AKZ1200/2-5.08-GREEN	51200020021 D	50
3	15.24	AKZ1200/3-5.08-GREEN	51200030021 D	50
4	20.32	AKZ1200/4-5.08-GREEN	51200040021 D	50
5	25.40	AKZ1200/5-5.08-GREEN	51200050021 D	50
6	30.48	AKZ1200/6-5.08-GREEN	51200060021 D	50
7	35.56	AKZ1200/7-5.08-GREEN	51200070021 D	50
8	40.64	AKZ1200/8-5.08-GREEN	51200080021 D	50
9	45.72	AKZ1200/9-5.08-GREEN	51200090021 D	50
10	50.80	AKZ1200/10-5.08-GREEN	51200100021 D	50
11	55.88	AKZ1200/11-5.08-GREEN	51200110021 D	50
12	60.96	AKZ1200/12-5.08-GREEN	51200120021 D	50
13	66.04	AKZ1200/13-5.08-GREEN	51200130021 D	50
14	71.12	AKZ1200/14-5.08-GREEN	51200140021 D	50
15	76.20	AKZ1200/15-5.08-GREEN	51200150021 D	50
16	81.28	AKZ1200/16-5.08-GREEN	51200160021 D	50

Accessoires

Figure	Designation	Article Number
	Coding Star CS4-5.0/5.08-RED	Order Data: 50000000026
	Series AKZ1200 with pull relief	Order Data: on request

Ratings

UseGroup	cRU [®] US			VDE	
	B	C	D		
Rated Voltage	300 V	150 V	300 V	250 V	
Rated Current	15 A	15 A	10 A	12 A	
Overtoltage Category				III	
Rated Wire Size				min	max
- solid	AWG 22-12	AWG 22-12	AWG 22-12	0.5 mm ² (5 A)	2.5 mm ² (12 A)
- stranded	AWG 22-12	AWG 22-12	AWG 22-12	0.5 mm ² (5 A)	2.5 mm ² (12 A)
Torque	0.50 Nm	0.50 Nm	0.50 Nm	0.50 Nm	
Screw Size	M2.5	M2.5	M2.5	M2.5	
Test Voltage	1.60 kV	1.30 kV	1.60 kV	4.0 kV	
Pollution Degree				3	